

ZL-7903A Temperature and Humidity Controller

V3.1c

Catalog

Feature	2
Main Function	2
Specification	2
Product Version.....	2
Key and Display.....	2
Key	3
Display.....	3
Buzzing.....	3
Key Operation	3
Fast Set Temperature (T11), Fast Set Humidity (H20)	3
Parameters Setting.....	3
Parameter Table	3
Control Function.....	5
On/offline set	5
Ventilation Fan (R2) Control	5
Door Control (according to door switch S1, optional function)	5
Temperature Control (R1, SSR)	5
R1 control (T10 = 0).....	5
External SSR hysteresis control (T10 = 1).....	5
External SSR PID control (T10 = 2)	5
High temperature protection.....	5
Humidity Control (R3).....	5
Humidify control (H10 = 1).....	5
Dehumidify control (H10 = 0)	5
High humidity protection	5
Egg-turning Control (R6, R7)	5
Mode 0 (U16 = 0):	5
Mode 1 (U16 = 1):	5
Egg turning times:	6
Check tray data:	6
Output R5 Control.....	6
R5 as periodical air exhaustion (U20 = 0).....	6
R5 as periodical air exhaustion + temperature and humidity high limit protection (U20 = 1)	6
R5 as periodical air exhaust + temperature high limit protection (U20 = 2)	6
R5 as periodical air exhaust + humidity high limit protection (U20 = 3).....	6
Output R4 Control.....	6
R4 as illumination control (U30 = 0)	6
R4 as Temperature and humidity high limit protection (U30 = 1).....	6
R4 as Temperature high limit protection (U30 = 2)	6
R4 as Humidity high limit protection (U30 = 3).....	6
Output R8 (R9) Control.....	6
R8 as alarm output (U40 = 0).....	6
R8 as Temperature and humidity high limit protection (U40 = 1).....	6
R8 as Temperature high limit protection (U40 = 2)	6
R8 as Humidity high limit protection (U40 = 3).....	6
Alarm.....	6
Alam temperature and humidity:	6
Alarm action.....	6
Auto Restart Function	7
Incubation Day Counter.....	7
Restore to Factory Default Settings.....	7
Fahrenheit/Celsius display.....	7
Manually Checking the Outputs One by One.....	7
Attention.....	7
Wiring Diagram	7
Dimension.....	8
Apendix: PID control.....	8

Feature

ZL-7901A is an industrial intelligent temperature and humidity controller. Optional external SSR to realize bigger heating power rate, and with optional temperature PID control. With touch button and big size LCD display, convenient to operate, easy to set up. Applicable for control of incubator, climate chamber, warehouse, and so on.

Main Function

1. Ventilation fan control
2. Door open/close check and control
3. Three temperature control modes: relays up/down limit control, SSR up/down limit control, SSR PID control
4. Humidify or dehumidify control
5. Timer air exhaust control
6. Timer egg turning control
7. Illumination control
8. Alarm output
9. Auto restart function
10. Temperature/humidity over limit warning and protection
11. Temperature/humidity sensor fault warning and protection

Specification

- ◇ Power supply: 100~240VAC, 50 or 60Hz
- ◇ Output and input:

Output				Input	
Main heater relay output	250VAC	7.5A / 1.0A*	Resistive load	R1	Temperature sensor: NTC, 5K/3470
Aux heater relay output		7.5A / 1.0A*		R10	Humidity sensor: ZL-SHr05J or ZL-SHr05P
Indoor ventilation relay output		7.5A		R2	
Humidity control relay output		7.5A**		R3	
Lamp control relay output		7.5A / 1.0A*		R4	
Air exhaust control relay output		3A		R5	
Egg turning relay output		1A		R6/R7	
Alarm output relay output		1A		R8/R9	
SSR driver output		20mA/10VDC MAX		Y+/Y-	

*. 7.5A rated current. **But for tungsten lamp, no more than 1.0A!**

** . If drive an adaptor (alternate voltage to DC12Vdc), it is in fact an AC/DC, with huge surging when power supplied, the output lifetime is not guaranteed.

- ◇ Setting range: humidity 0 ~ 99% RH, temperature 0 ~ 100°C. ZL-SHr05J is for 0-80%RH, ZL-SHr05P is for 0-99%RH.
- ◇ Accuracy: temperature 1% @25°C, humidity: 3%RH with ZL-SHr04J, 2%RH with ZL-SHr04P
- ◇ Working environment: -20 ~ 45°C, 10 ~ 90% RH without dewing

Product Version



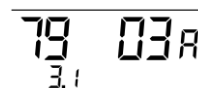

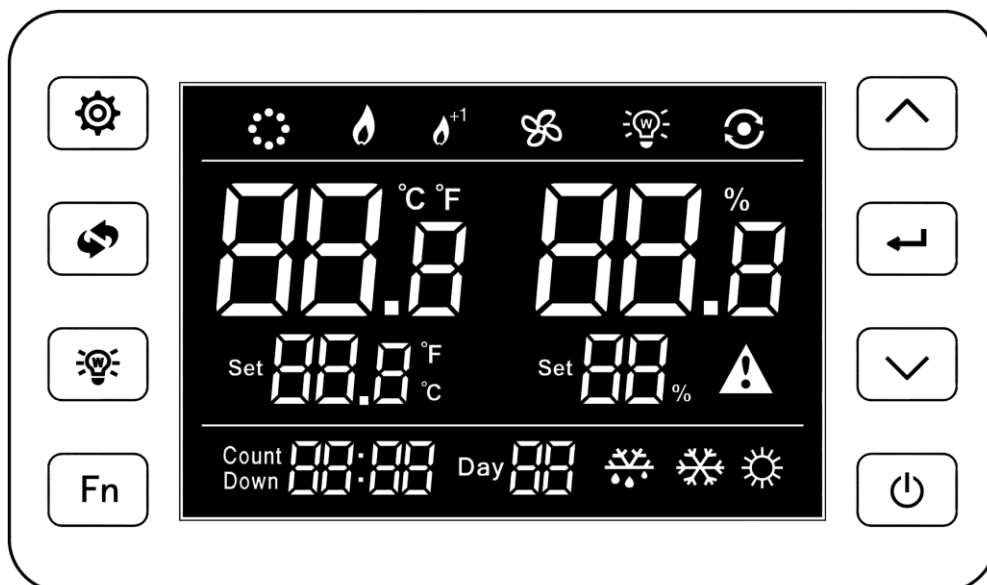

When power supplied, the controller will display model and firmware version: **ZL-7903A, version 3.1:**









Key and Display



Key

Key	Function	Remark
	Power	Keep depressed for 3 seconds to turn online/offline
	Set	Short press to switch between humidity set and temperature set; Long press to set other parameters (see Parameter Table below)
	+	Increase the set value. Keep depressed for fast set
	-	Decrease the set value. Keep depressed for fast set
	Enter	Confirmation
	Reset	Short press for cancel and return; Long press to clear incubating accumulated days counter
	Lamp	Turn the lamp off/on
Fn	Fn	Combination key

Display



Icon	Function	On	Off	Blinking
	Humidify/dehumidify state	Energized	De-energized	
	Main heater	Energized	De-energized	
	Auxiliary heater	Energized	De-energized	
	Air exhaust	Energized	De-energized	
	Egg turning motor, turn right	Energized	De-energized	
	Egg turning motor, turn left	Energized	De-energized	
	Warning	---	No warning	Warning
E01	Temperature sensor fault	Warning	No warning	
E02	Humidity sensor fault	Warning	No warning	
tHi	Temperature higher than up limit	Warning	No warning	
tLo	Temperature lower than down limit	Warning	No warning	
HHi	Humidity higher than up limit	Warning	No warning	
HLo	Humidity lower than down limit	Warning	No warning	
UnL	Restore to default parameters	Restoring to default parameters		
dr	Door is opened	Door open		

Buzzing

Every key press, there will be a beep.

When there is error of sensors, high/low limit temperature or humidity warning, there will be buzzing warning. Any key press can stop the warning.



Key Operation
Fast Set Temperature (T11), Fast Set Humidity (H20)



Press  to switch between temperature and humidity setting. Press  and  to set the value.

Press  to save the setting.



Press , or without key operation for 30 seconds, exit the mode, and the set value is not saved.

Parameters Setting

Keep  and  depressed simultaneously for 3 seconds. LCD shows "Psd 000".

Press  and  to enter password (default "000"). Press  to confirm.

If the password is correct, enter into parameter setting mode, else exit.

Press  to select parameter code, press  and  to set the value, press  to save the setting.



Press , or without key operation for 30 seconds, exit the mode, and the set value is not saved.

Parameter Table

Code	Function	Range	Unit	Indication	Default
T10	Temperature control working mode	0 ~ 2		0: R1 and R10 up/down limit control 1: External SSR, up/down limit control 2: External SSR, PID control	0
T11	Temperature setpoint	0.0 ~ 100.0			37.8
T12	Temperature hysteresis for R1 (T10 = 0)	0.0 ~ 20.0	°C/°F	Relative to T11, absolute value: T11 - T12	0.2
T13	Temperature hysteresis for R10(when T10 = 0), or SSR (when T10 = 1)	0.0 ~ 20.0		Relative to T11, absolute value: T11 - T13	0.3
T14	Min stop time for temperature load (R1)	0 ~ 999	sec		1
T15	Min stop time for temperature load (R10)	0 ~ 999	sec		1
T20	Temperature calibration	-9.9 ~ +9.9	°C/°F		0.0
T21	High temp. alarm relative point	0.0 ~ 65.0/dis	°C/°F	dis: disable warning. Absolute point = T11 + T21	dis
T22	Low temp. alarm relative point	0.0 ~ 65.0/dis		dis: disable warning. Absolute point = T11 - T22	dis
T25	High temp. protection relative point	0.0 ~ 65.0/dis		dis: disable warning. Absolute point = T11 + T25 Ref.: U20 = 1/2/3, U30 = 1/2/3, U40 = 1/2/3	0.2
T26	Hysteresis for T25	0.0 ~ 65.0		Absolute point = T11+T25-T26 Ref.: U20 = 1/2/3, U30 = 1/2/3, U40 = 1/2/3	0.1
T30	Proportion of SSR PID	0.1 ~ 5000	Power/C	Kp for PID	39.3
T31	Integration of SSR PID	0 ~ 5000	sec	Ti for PID. If Ti = 0, shut integration.	15.7
T32	Differential of SSR PID	0 ~ 5000		Td for PID. If Td =0, shut differential.	40.5
H10	Dehumidify / humidify mode	0 / 1		0: dehumidify, 1: humidify	1
H20	Humidity setpoint	0 ~ 99			50
H21	Humidity hysteresis	0 ~ 50	%RH	Relative to H20, absolute value: H20 - H21	5
H22	Humidity calibration	-9.9 ~ +9.9			0.0
H23	Minimum stop time for humidity load (R3)	0 ~ 30	min		0
H24	High humidity warning relative point	0 ~ 80/dis	%RH	dis: disable warning. Absolute point = H20 + H24	dis
H25	Low humidity warning relative point	0 ~ 80/dis		dis: disable warning. Absolute point = H20 - H25	dis
H26	High humidity protection relative point	0 ~ 80/dis		dis: disable warning. Absolute point = H20 + H26 Ref.: U20 = 1/2/3, U30 = 1/2/3, U40 = 1/2/3	5
H27	Hysteresis for H26	0 ~ 80		Absolute point = H20-H26-H27 Ref.: U20 = 1/2/3, U30 = 1/2/3, U40 = 1/2/3	2
U10	Left turn (R6) time unit	1 ~ 2		1: minute, 2: hour	1
U11	Left turn (R6) time of the timer	1 ~ 999			120
U12	Right turn (R7) time unit	1 ~ 2		1: minute, 2: hour	1
U13	Right turn (R7) time of the timer	1 ~ 999			120
U14	Turning times	0 ~ 999		0: unlimited turning times	0
U16	Turning motor working mode	0 / 1		0: Either R6 or R7 will be energized. Need position switches, position arrival shuts off the power supply to motor 1: Only energized during turning moment (U17). Manual egg turning support	1
U17	Motor being energized time for every turning	0 ~ 999	sec	Effective only when U16 = 1	30
U18	Hatching days	0 ~ 99	day	0: disabled hatching days counting	0
U20	Output R5 (air exhaustion) control mode	0 ~ 3		0: Air exhaust 1: Air exhaust + humi./temp. high limit protection 2: Air exhaust + temperature high limit protection 3: Air exhaust + humidity high limit protection	1
U21	Time unit for air exhaust period (R5)	0 ~ 2		0: second, 1: minute, 2: hour	1
U22	Air exhaust period (R5)	1 ~ 999			30
U23	Time unit for air exhausting time (R5)	0 ~ 2		0: second, 1: minute, 2: hour	0
U24	Air exhausting time (R5)	1 ~ 999			30
U30	Output R4 (Lamp or protection) control mode	0 ~ 3		0: illumination control 1: temperature and humidity high limit protection 2: Temperature high limit protection 3: humidity high limit protection	0
U34	Output R4 delay time for automatic shutdown	1 ~ 999	Min	Only effective when U30 = 0	2
U40	Output R8 (alarm or protection) control mode	0 ~ 3		0 = alarm output 1 = temperature and humidity High limit protection 2 = temperature high limit protection 3 = humidity high limit protection	0
U50	Door switch mode	0 / 1		0: Normal close, 1: Normal open	0
U65	Buzzing warning option	0 / 1		0: disable warning, 1: enable warning	1
U90	Password	000 ~ 999		000 = no password	0
U93	PID self auto tune power rate	10 ~ 100	%	Percent of heater's full power rate	50

Control Function

On/offline set

Keep  depressed for 3 seconds to switch between  online and offline. The controlling only works when online.

Ventilation Fan (R2) Control

When online, ventilation is on.

When offline, or door is open, ventilation stops.

Door Control (according to door switch S1, optional function)

Parameter U50 set the switch control mode:

Normal open: U50 = 1: When door is open, the door switch is open. When door is closed, the switch is short inside.

Normal close: U50 = 0: When door is closed, the door switch is short inside. When door is open, the switch is open.

Factory setting: U50 = 0. **In this setting, if without a door switch, the controller thinks the door is closed always.**

When door is just opened, the lamp will be on for U34 (under setting U30 = 0), even in offline status.

When door is just closed, the lamp will be off.

When door is open: heater and ventilation are off, egg tray stops. If U16 = 1, manual egg tray control is still effective.

When door is closed: heater can work, ventilation is on, egg tray can work automatically.

Temperature Control (R1, R10, SSR)

Relay R1 and R10 control (T10 = 0)

If room temperature \geq T11, R1 will be de-energized.

If room temperature \leq (T11 - T12), and R1 has been stopped for T14, R1 will be energized.

If room temperature \geq (T11 - T13), R10 will be de-energized.

If room temperature $<$ (T11 - T1), and R10 has been stopped for T15, R10 will be energized.

External SSR hysteresis control (T10 = 1)

If room temperature \geq T11, SSR will be de-energized.

If room temperature $<$ T11, SSR will be energized.

SSR power rate:

When room temperature \geq (T11 - T13), SSR output is: U93 * full power rate.

When room temperature $<$ (T11 - T13), SSR output is full power rate.

Example: if U93 = 50, the power rate is 50% of full power rate.

External SSR PID control (T10 = 2)

See paragraph Appendix: PID control

High temperature protection

Protection reaction could be R5, R4 or R8, depends on settings.

When room temperature \geq (T11 + T25), start protecting.

When room temperature \leq (T11 + T25 - T26), stop protecting.

Humidity Control (R3)

Humidify control (H10 = 1)

If room humidity \leq (H20 - H21), and R3 has stopped for H23, R3 will be energized.

If room humidity \geq H20, R3 will be de-energized.

Dehumidify control (H10 = 0)

If room humidity \geq (H20 + H21), and R3 has stopped for H23, R3 will be energized.

If room humidity \leq H20, R3 will be de-energized.

High humidity protection

Protection reaction could be R5, R4 or R8, depends on settings.

When room humidity \geq (H20 + H26), start protecting.

When room humidity \leq (H20 + H26 - T27), stop protecting.

Egg-turning Control (R6, R7)

Mode 0 (U16 = 0):

Either R6 or R7 will be energized, need position switches, manual turning does not work.

When left turning time (U11) arrives, R6 energized, R7 de-energized.

When right turning time (U13) arrives, R7 energized, R6 de-energized.



Mode 1 (U16 = 1):



R6 and R7 is not energized when no turning, manual turning works.



When left turning time (U11) arrives, R6 energized for U17.



When right turning time (U13) arrives, R7 energized for U17.

Manual turning:

Keep  and  depressed simultaneously for 3 second to enter into the mode, R6 and R7 will be de-energized, the  display will be flashing;

If keep  depressed, R6 energized,  displayed;

If keep  depressed, R7 energized,  displayed;

Keep  and  depressed simultaneously for 3 sec, or no key operation for 30 sec will exit the mode.

Egg turning times:

R6 starts once + R7 starts once = turning once. When egg turning times reaches U14, turning will not start any more. If turning times (U14) = 0, turning will never stop.

Check tray data:

Left times of egg turning and time to the next egg turning:

When turning times (U14) \neq 0, the *left times of egg turning* and *time to the next egg turning* will display alternatively. When the *accumulated times of egg turning* \geq U14, LCD will display "STOP", there will be no egg turning.

Keeping  depressed for 3 seconds will reset the *accumulated times of egg turning* and *incubation day counter*.

When turning times (U14) = 0, the egg turning will never stop. LCD will display *time to the next egg turning*.

Output R5 Control

R5 as periodical air exhaustion (U20 = 0)

When U22 arrives, R5 is energized.

When U24 arrives, R5 is de-energized.

R5 as periodical air exhaustion + temperature and humidity high limit protection (U20 = 1)

When there is no warning, exhaust air periodically.

If room temp. \geq T11 + T25, or room humidity \geq H20 + H26, R5 energized.

If room temp. \leq T11 + T25 - T26, and room humidity \leq H20 + H26 - H27, stop protection.

R5 as periodical air exhaust + temperature high limit protection (U20 = 2)

When there is no warning, exhaust air periodically.

If room temp. \geq T11 + T25, R5 energized.

If room temp. \leq T11 + T25 - T26, stop protection.

R5 as periodical air exhaust + humidity high limit protection (U20 = 3)

When there is no warning, exhaust air periodically.

If room humidity \geq H20 + H26, R5 energized.

If room humidity \leq H20 + H26 - H27, stop protection.

Output R4 Control

R4 as illumination control (U30 = 0)

Press  to turn the lamp on/off. When the lamp is turned on, it will be off after U34 automatically.

Under this setting,

When door is opened, R4 will be energized for U34 time. When door is closed, R4 will be de-energized.

R4 as Temperature and humidity high limit protection (U30 = 1)

If room temp. \geq T11 + T25, or room humidity \geq H20 + H26, R4 energized.

If room temp. \leq T11 + T25 - T26, and room humidity \leq H20 + H26 - H27, stop protection.

R4 as Temperature high limit protection (U30 = 2)

If room temp. \geq T11 + T25, R4 energized.

If room temp. \leq T11 + T25 - T26, stop protection.

R4 as Humidity high limit protection (U30 = 3)

If room humidity \geq H20 + H26, R4 energized.

If room humidity \leq H20 + H26 - H27, stop protection.

Output R8 (R9) Control

R8 as alarm output (U40 = 0)

R8 will be energized when there is alarming. Alarming definition: see paragraph **Alarm**

R8 as Temperature and humidity high limit protection (U40 = 1)

If room temp. \geq T11 + T25, or room humidity \geq H20 + H26, R8 energized.

If room temp. \leq T11 + T25 - T26, and room humidity \leq H20 + H26 - H27, stop protection.

R8 as Temperature high limit protection (U40 = 2)

If room temp. \geq T11 + T25, R8 energized.

If room temp. \leq T11 + T25 - T26, stop protection.

R8 as Humidity high limit protection (U40 = 3)

If room humidity \geq H20 + H26, R8 energized.

If room humidity \leq H20 + H26 - H27, stop protection.

Alarm

Alarm temperature and humidity:

High temperature alarming, when room temp. \geq T11 + T21.

Low temperature alarming, when room temp. \leq T11 - T22

High humidity alarming, when room humidity \geq H20 + H24.

Low humidity alarming, when room humidity \leq H20 - H25

Alarm action

When there is alarm:

R8 energized (when U40 = 0).

Buzzing (could be stopped by any key press).

Display the reason table:

Code	Remark	Real time detection	Delay	Duration	Reset	Action
E01	Temperature sensor failure	Yes	0 sec	6 sec	Auto	Alarming, temperature output de-energized, the other control not affected
E02	Humidity sensor failure	Yes	0 sec	6 sec	Auto	Alarming, humidity output de-energized, the other control not affected
tHi	High temperature	Yes	0 sec	5 sec	Auto	Alarming
tLo	Low temperature	Yes	0 sec	5 sec	Auto	Alarming
HHi	High humidity	Yes	0 sec	5 sec	Auto	Alarming
HLo	Low humidity	Yes	0 sec	5 sec	Auto	Alarming
dr	Door open	Yes	0 sec	1 sec	Auto	Related alarming, temperature output de-energized, ventilation de-energized, humidity control output de-energized, lamp on for U34 (when U30 = 0)
iCE	Touched IC fault	Yes	0 sec	5 sec	Auto	

Auto Restart Function

After power supply stops, and comes back, the controller will run under the same settings and status.

Incubation Day Counter

When controlling, the *incubation day counter* will keep counting.

If the counter value reaches U18, controller keeps controlling as normal, and the counter value will be flashing.

If the counter value reaches 99, stop counting. Keeping depressed for 3 seconds will reset the *accumulated times of egg turning* and *incubation day counter*.

Restore to Factory Default Settings

When the controller is online, keep Fn and depressed simultaneously for 3 seconds. The display shows "UnL". Then press twice, the controller will restore the parameters to factory default settings.

Fahrenheit/Celsius display

Keep Fn and depressed simultaneously for 3 seconds to switch between Fahrenheit / Celsius display.

Manually Checking the Outputs One by One

Keep Fn depressed for 3 seconds, LCD displays "CCC". Then press twice to enter into manual checking mode. Now all outputs are de-energized. Press and to energize R1/R2/R3/R4/R5/R6/R7/SSR in turn.

Attention

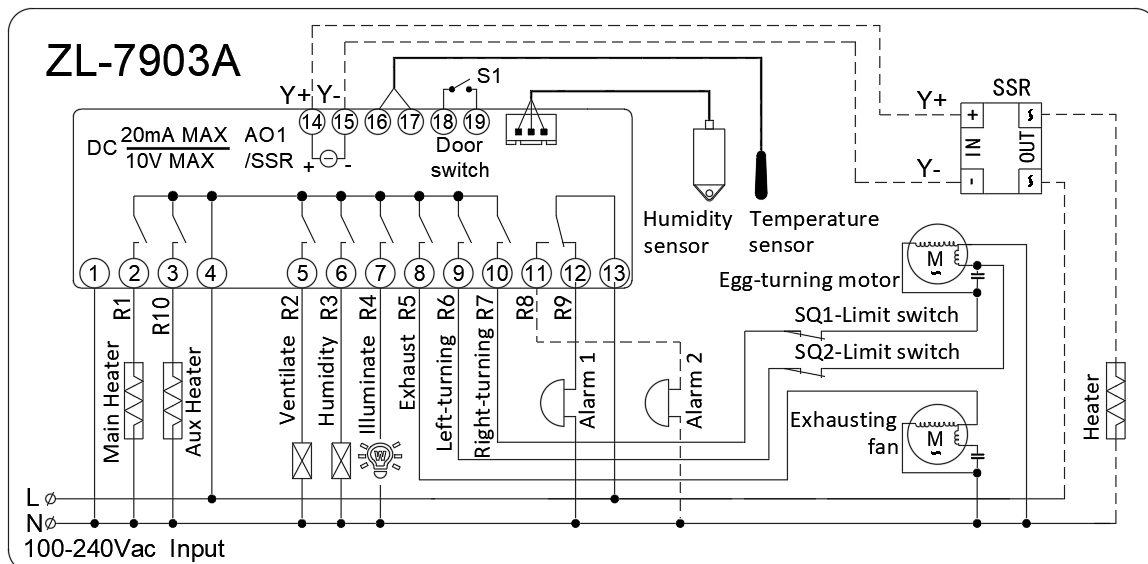

1. Please read this instruction carefully. Electrical wiring must be manipulated by certified electrician. Wrong wiring may damage the device and system seriously.
2. Avoid humid environment, or with corrosive gases, or strong electric-magnetic field. The device is possible abnormal in such condition.
3. This product has been strictly tested before shipping. The company warranty is one year, the responsibility is limited to the sale of the product itself. Damage caused by improper usage is not covered by the warranty.

Wiring Diagram

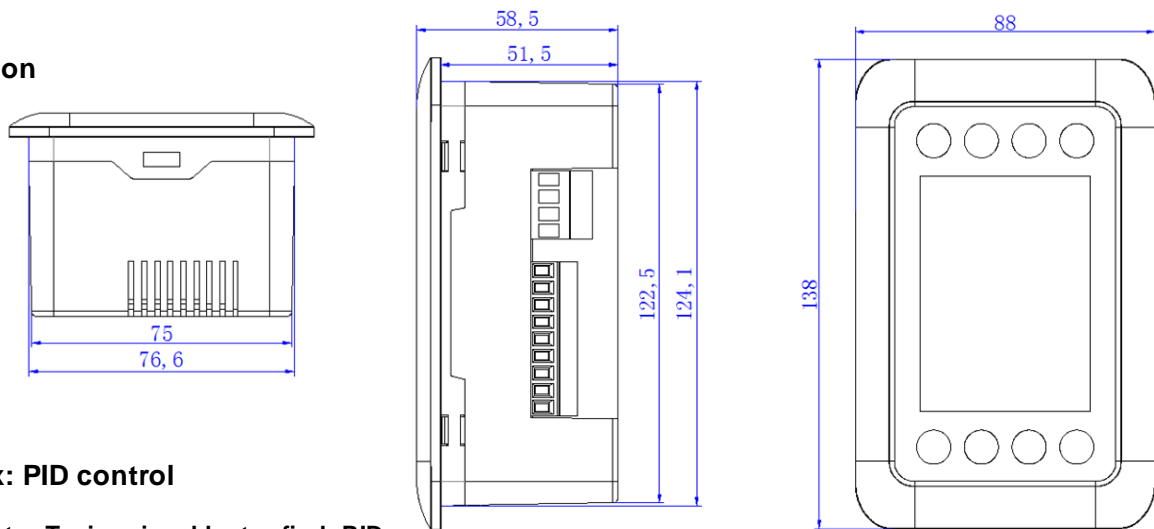

Dimension

Appendix: PID control

Auto Tuning is able to find PID parameters (Kp/Ti/Td, U30/31/32) automatically for most control system

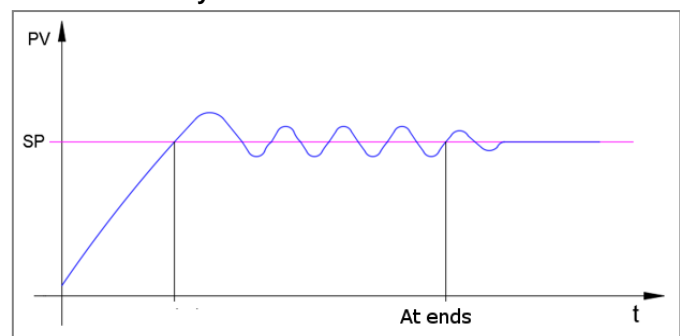
1. Set power rate during auto tuning (U93).
 2. Set set-point during auto tuning (SP, T11).
- When not in set mode, keep Fn and  depressed simultaneously for 5 seconds to enter into self auto tuning mode: LCD will display "Pid". Press  to start tuning. Then LCD will display "At".
- After the room temperature (PV) reached SP, it will vibrate around SP for several times. The controller will calculate the PID parameters (Kp/Ti/Td, U30/31/32) according to these PV data. And the "At" display disappears.

Note:
a. PID control, or hysteresis control?

Try hysteresis control 1st (T10 = 1):

- Now is full power rate heating. If PV is not able to reach SP within reasonable time, increase heater power rate.
- If PV overshoot to $SP \leq 0.2^\circ\text{C}$, or over falling to $(SP - T12) \leq 0.2^\circ\text{C}$: auto tuning is not able to get the PID parameters correctly.
- If all are ok, try PID auto tuning.

Try auto tuning (T10 = 2, start auto tuning):

Now the heating power rate is U93 percent of the heater's power rate. Default U93 = 50.

If PV is not able to reach SP within reasonable time, increase U93 value, or increase heater power rate.

If the overshoot or over falling to $SP \leq 0.2^\circ\text{C}$, auto tuning is not able to get the PID parameters correctly.

The following will also make auto tuning failure, or get wrong PID parameters:

- The PV vibration amplitudes differ too much.
- The PV vibration periods differ too much.
- The PV changes not smoothly (there are temperature interference, like opened door at some moment).

b. Try to get best parameters

If make 2 auto tuning, the tuned PID parameters are similar, we could use the average data for application.

If the 2 tuned data are not similar, auto tuning the 3rd times.

When the environment temperature, or object inside (empty box and box with goods inside are not same system), or air flow speed inside changed greatly, it needs auto tuning again.

c. About PTC heating element

PTC has a Curie point parameter. When PTC's temperature is high than Curie point, its power rate will be reduced to almost zero, the PID control will fail.

With higher Curie PTC heater, with good dissipator for heater, with high air flow speed around heater to avoid the failure.

d. Manual tuning principle

Manual tuning could revise the control result. $Kp = U30$, $Ti = U31$, $Td = U32$.

Increase Kp, increase the speed of control, but more overshoot and bigger vibration.

Increase Ti, get more accurate temperature, but need longer time to reach SP after stating heating.

Increase Td, fast reaction to control, but add more "noise" to the control result.