

# ZL-807A Controller

Instruction Manual V1.0b

## Catalog

<b>Feature .....</b>	<b>2</b>
<b>Function .....</b>	<b>2</b>
<b>Specification .....</b>	<b>2</b>
<b>Display.....</b>	<b>2</b>
Panel .....	2
Display indication.....	2
Alarming code.....	3
<b>Operation .....</b>	<b>3</b>
Set setpoint.....	3
Set parameter.....	3
Check pipe temperature.....	3
Parameter code table.....	3
<b>Control.....</b>	<b>3</b>
On/Offline control.....	3
Cooling only mode (F01 = 1).....	3
Constant temperature mode (F01 = 0).....	4
Heat by compressor (F02 = 0).....	4
Heat by electrical heater (F02 = 1).....	4
Defrost (F02 = 0, and under heating mode).....	4
Forced defrost (F02 = 0, under heating mode).....	4
Fast launch (Force the compressor energized).....	4
Pump control.....	4
External alarm input.....	4
Delay protection for compressor.....	4
Auto restart.....	4
Calibration.....	4
Waring for sensor failure.....	4
Restore to factory settings.....	5
<b>Wiring diagram .....</b>	<b>5</b>
Diagram one: heating by compressor.....	5
Diagram two: heating by heater.....	5
<b>Dimension .....</b>	<b>6</b>
Out size.....	6
Embedded hole.....	6
If the cable protection rubbers could be removed during installation.....	6
If the cable protection rubbers could not be removed during installation.....	6

# ZL-807A Controller

## Instruction Manual V1.0b

### Feature

ZL-807A is water temperature controller. It could work in cooling mode, or constant temperature control mode. It can drive 2 HP compressor directly. And it has water pump on/off control function. With IP60 panel, friendly to operate, easy to install. It could control sea food chiller, aquarium pool, or water tank's temperature.

### Function

- Control mode: constant temperature, cooling only.
  - Heating method: by compressor, by electrical heater.
  - Periodic defrost (when install 1 sensor).  
Intelligent defrost (when install 2 sensors)
    - \* Default packing is with one sensor.
    - \* Pipe sensor could be purchased standalone.
  - Water pump on/off control
  - Compressor delay protection
  - Instant start compressor
  - Temperature calibration
  - Sensor failure warning
  - External warning input
  - Auto restart for power supply failure
- Pipe sensor can be found by controller when installed.  
If the outdoor evaporator frosts serious, 2 sensors is better.  
With 2 sensors, we can check outdoor pipe temperature.

### Specification

- Power supply: 100 ~ 240Vac, 50/60Hz
- Outputs:
  - Compressor: 40A/250Vac relay, can drive 2HP compressor.
  - Valve/Heater: 5A/250Vac, resistance.
  - Fan: 5A/250Vac, resistance.
  - Pump: 5A/250Vac, resistance.
- Set range: -9.9 ~ 65.0°C
- Display range: -9.9 ~ 70.0°C
- Working: -10 ~ 45°C, <85%RH without dew
- Deposit: -30 ~ 70°C
- Case: fireproof ABS
- Protection level: IP60
- Sensor: NTC, 5K@25°C, B=3470K.
  - Water sensor, plastic sealed, 5 meters cable.
  - Pipe sensor, copper sealed nickel coated, 2 meters cable.
- Size: See last page of this manual.

### Display Panel



### Display indication

Lamp	On	Off	Blinking
OnOff (red)	Online	Offline	Alarming
SET (yellow)	Setting temperature		Setting parameters
PUMP (green)	Pump energized	Pump de-energized	
COOL (green)	Cooling		Under delay protection
HEAT (red)	Heating		
DEF (yellow)	Defrosting		Forced defrosting

## Alarming code

Code	Remark
E1	Water sensor failure
E2	Defrost sensor failure
E3	External alarming (all controller outputs will be de-energized)

## Operation

### Set setpoint

Enter into temperature setting status: Keep **【SET】** depressed for 3 seconds.

The SET lamp will be on. The current setpoint displays.

Press **【▲】** or **【▼】** to set setpoint. (keep the keys depressed can fast setting)

Keep **【SET】** depressed for 3 seconds, exit the setting status, the setting will **be saved**.

The setting status will exit, the set value will **not be saved**, if there is no key operation for 10 seconds.

### Set parameter

Enter into parameter setting status: Successively and fast press **【▲】【▼】【▲】【▼】【▲】【▲】【▼】**, like input password.

The SET lamp will be blinking. The 1<sup>st</sup> parameter code "F01" displays.

Press **【▲】** or **【▼】** to select code (F01, F02, F03, ...).

Press **【SET】** to display the value of the code.

Press **【▲】** or **【▼】** to set the value of the code. (keep the keys depressed can fast setting)

Press **【SET】** to return to parameter code display.

By this, all code could be set.

Keep **【SET】** depressed for 3 seconds, exit the setting status, the settings will **be saved**.

The setting status will exit, the set values will **not be saved**, if there is no key operation for 30 seconds.

### Check pipe temperature

In online status, short press **【🔌】** will blinkingly show pipe temperature for 10 seconds.

Short press **【🔌】** could stop show the pipe temperature.

### Parameter code table

Code	Function	Setting range	Remark	Factory
F01	Temperature control mode	0/1	0: constant temperature 1: cooling only	0
F02	Heating mode	0/1	0: by compressor 1: by electrical heater	0
F03	Hysteresis	0.1 ~ 20.0℃		1.0
F04	Calibration for water sensor	-9.9 ~ 9.9℃		0.0
F05	Calibration for pipe sensor	-9.9 ~ 9.9℃		0.0
F06	Delay protection for compressor	0 ~ 10 min		3
F07	Temperature for start defrost	-20 ~ 20℃		-5
F08	Temperature for stop defrost	-20 ~ 20℃	If F08 ≤ F07, disable defrost function	10
F09	Max defrost time	0 ~ 60 min		5
F10	Min time to start defrost (1)	0 ~ 600 min	0: disable defrost function	30
F11	Buzzing alarm (2)	0/1	0: disable 1: enable	0
F12	External alarm setting	0 ~ 2	0: disable 1: Effective when short 2: Effective when open	0
F13	Delay for external alarm	0 ~ 120 sec		3

Note: (1) The continuous energized time for compressor. (2) When alarming buzzing, it could stop by press any key.

## Control

### On/Offline control

Keep **【🔌】** depressed for 3 seconds to switch between online and offline.

### Cooling only mode (F01 = 1)

If (water temperature) ≥ (setpoint + F03), and the compressor has stopped for F06, the compressor energized.

If (water temperature) ≤ (setpoint), the compressor de-energized.

Control sequence: Compressor on, fan will be on after 10 seconds. Compressor off, fan will be off after 5 seconds.

## Constant temperature mode (F01 = 0)

### Heat by compressor (F02 = 0)

If (water temperature)  $\geq$  (setpoint + F03), and the compressor has stopped for F06, the compressor starts cooling.

If (water temperature)  $\leq$  (setpoint), the compressor de-energized.

If (water temperature)  $\leq$  (setpoint-F03), and the compressor has stopped for F06, the compressor starts heating.

If (water temperature)  $\geq$  (setpoint), the compressor de-energized.

Control sequence: Compressor on, fan will be on after 10 seconds. Compressor off, fan will be off after 5 seconds.

Heating cooling change sequence: the compressor will be energized 15 seconds after 4-way valve is set.

### Heat by electrical heater (F02 = 1)

If (water temperature)  $\geq$  (setpoint + F03), and the compressor has stopped for F06, the compressor energized.

If (water temperature)  $\leq$  (setpoint), the compressor de-energized.

If (water temperature)  $\leq$  (setpoint-F03), the heater energized.

If (water temperature)  $\geq$  (setpoint), the heater de-energized.

Control sequence: Compressor on, fan will be on after 10 seconds. Compressor off, fan will be off after 5 seconds.

## Defrost (F02 = 0, and under heating mode)

### Intelligent defrost

If (pipe temperature)  $\leq$  F07, and the compressor has been energized for F10, start defrost.

If (pipe temperature)  $\geq$  F08, or (the defrosting time)  $\geq$  F09, stop defrost.

### Periodic defrost

Without defrost sensor, or when defrost sensor fails, the controller will defrost periodically.

When the compressor has been energized for F10, start defrost.

When defrosting time reaches F09, defrost ends.

### Defrost procedure

Compressor stops→valve switches after 30 seconds→compressor starts for defrost after 30 seconds→compressor stops when F08 or F09 condition meets→valve switches after 30 seconds→start compressor heating after 30 seconds.

Fan stops during defrosting.

## Forced defrost (F02 = 0, under heating mode)

Keep **▲** and **▼** depressed simultaneously for one second to enter into forced defrosting.

\* Forced defrosting works the same way as periodical defrost.

\* Once launched forced defrost, it will not stop, till the full process finished.

\* Fan stops during forced defrosting.

## Fast launch (Force the compressor energized)

Launch: when online, keep **☺** and **S** depressed simultaneously for 6 seconds, there will be 3 short beeps and 1 long beep, and the compressor will be energized.

The controller will keep working as the set of F01 for 90 seconds, then exit the status.

Stop: It can stop and exit by keeping **☺** and **S** depressed simultaneously for 6 seconds.

## Pump control

When online, keep **PUMP** depressed for 3 seconds to switch pump on/off.

\* When power supplied, pump works in the same status as that of previous power supplied.

\* Press **☺** to shut to offline, the pump will stop. **Press **☺** to switch to online, the pump keeps off!**

\* External alarm does not influence the pump status.

## External alarm input

F12 = 0, disable external alarm function.

F12 = 1, when short for F13 time, alarming.

F12 = 2, when open for F13 time, alarming.

During alarming, all outputs except pump de-energized, buzzing, E3 displays, power lamp blinking.

## Delay protection for compressor

Every time, the power supplied, the compressor is possible to be energized after F06 time.

Every time, the compressor is de-energized, it is possible to be energized after F06 time.

## Auto restart

When power supply loses, and then come back, the controller will work in the same status as that before power loses.

## Calibration

By setting F04/F05, we can compensate the error of the sensors.

## Warning for sensor failure

When water sensor fails, display E1, compressor/valve or heater/fan will be de-energized, beeping, OnOff lamp blinking.

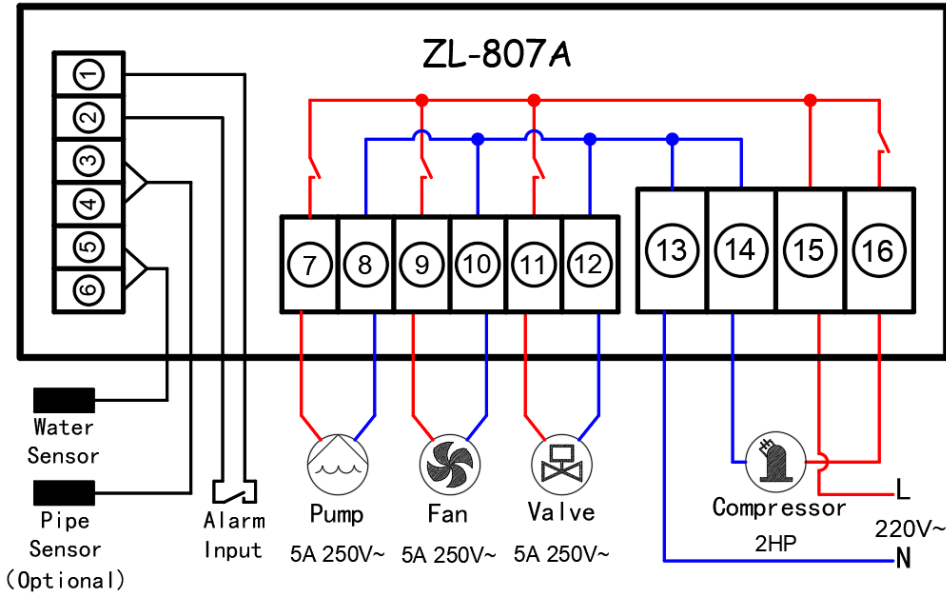
When pipe sensor fails, display E2.

**Restore to factory settings**

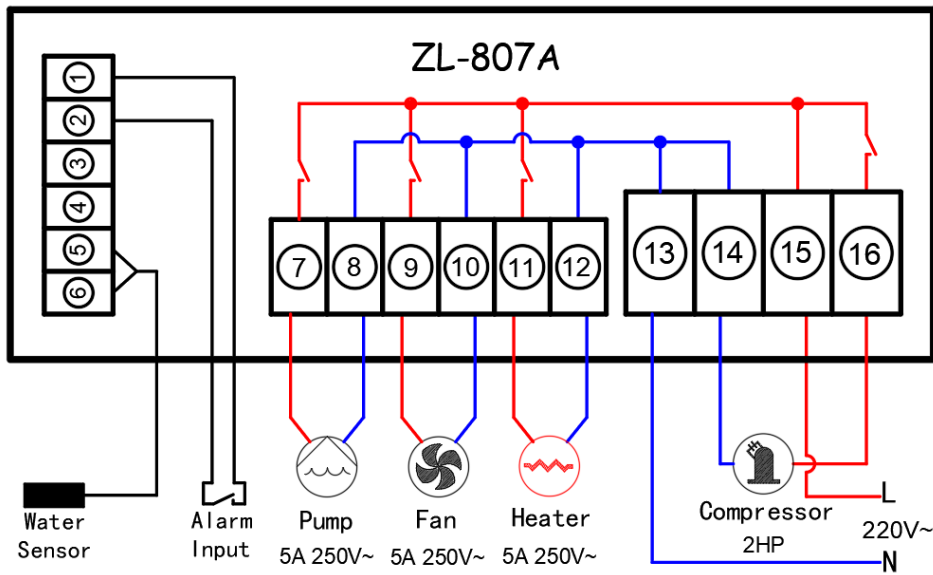
Keep **【SET】** and **【▲】** depressed simultaneously for 2 seconds, display “UnL”.  
 Press **【▼】** twice, all settings will restore to factory default values.

**Wiring diagram**

**Diagram one: heating by compressor**

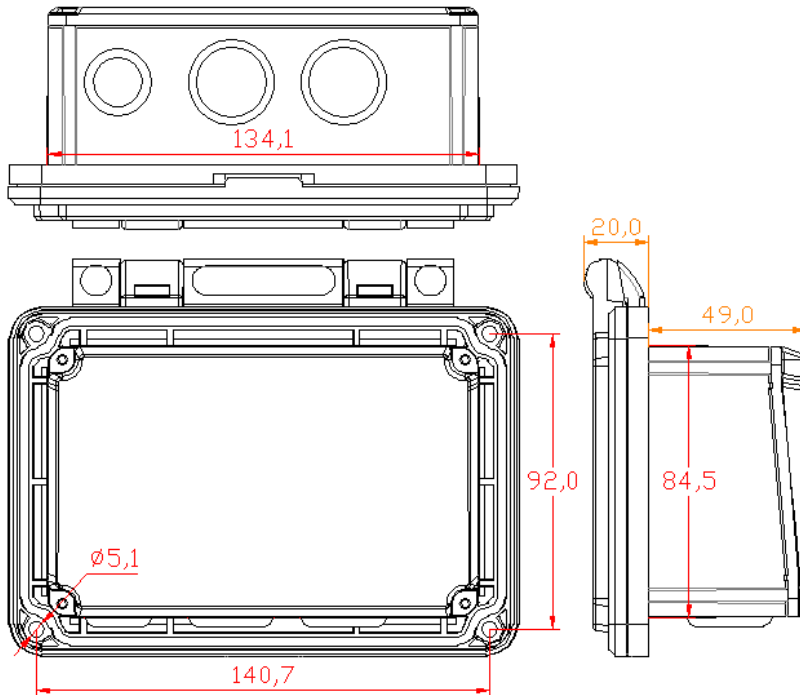


**Diagram two: heating by heater**



**Dimension**

**Case size**

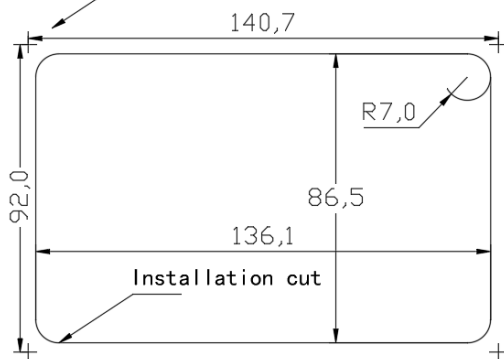


**Embedded hole**

**If the cable protection rubbers could be removed during installation**

Hole size = 136.1 \* 86.5 mm, R = 7 mm

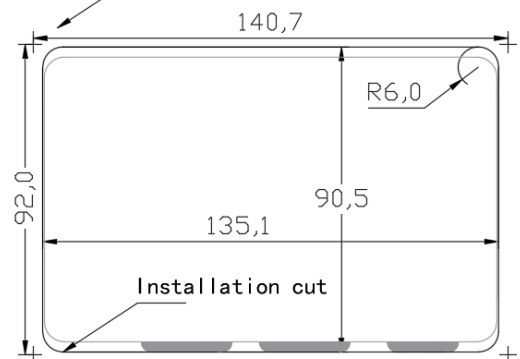
Fix position X 4



**If the cable protection rubbers could not be removed during installation**

Hole size: 135.1 \* 90.5 mm, R = 6 mm

Fix position X 4



**Install:**

