

# ZL-680A Temperature Controller

## Version A1.0b

### Introduction

ZL-680A is a thermostat with cooling and heating option. With defrost function, it is suitable for cold storage, as well as normal cooling and heating control.

### Main Specification

Sensor wire: 2 meters long

Sensor: NTC, 5K  $\Omega$  @25°C, B=3470

Setting range: -50~110°C (-50~199°F)

Display range: -99~199°C (-99~199°F)

Resolution: 0.1°C (between -19.9~19.9°C)

Power supply: 230Vac, 50/60Hz

Load: 16A, 250Vac (resistance)

Working: -20~55°C

Working: 10~90% RH without dew

Case materials: PC + ABS fire proof

Protection level: IP65 (Front side only)





Dimension: L78 x W34.5 x D71 (mm)

Installation drilling: L71 x W29 (mm)

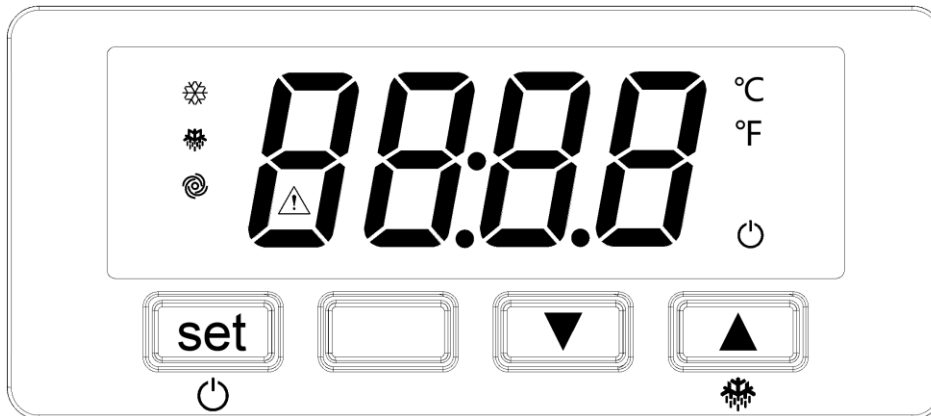
Input: 5Vdc, 1mA

### Display



Icon	Function	On	Blink
	Control Load	Load energized	Delay protecting, or setting set-point
	Defrost	Defrosting	
	Warn	Warning	
°C	Celsius	Digit is Celsius	
°F	Fahrenheit	Digit is Fahrenheit	
	Offline	Being offline	

Display	Function	Display	Function
P1	Sensor failure	IA	Input warning
AL	Low temperature warning	Id	Door warning
AH	High temperature warning	Lo	Keypad locked

## Operation

### Set Set-Point

Press **[set]** key,  blinks.

Press **[▲]** or **[▼]** to set the set-point (keeping depressed can fast set).

Press **[set]** to exit, and save the setting.

Note: The status will exit, and the settings will be saved, if no key operation within 30 seconds.

The set range is between system parameters r1 and r2, see table below.

The set-point could be also set by setting system parameter SP.

### Set System Parameters

Keeping **[▲]** and **[▼]** depressed simultaneously for 3 second to enter into/exit (save) the setting status. After entering into the setting status, the system parameter code SP displays.

Press **[▲]** or **[▼]** to select the code.

Press **[set]** to display its value.

Press **[▲]** or **[▼]** to set its value.

Press **[set]** key, or do not press key for 15 seconds, to return to code selection.

Note: The setting status will exit if no key operation for 30 seconds, and the settings will be saved.

### System Parameter Code Table

Code	Function	Range	Unit	Note	Default
SP	Set-point	r1 ~ r2	°C/°F		0.0
o1	Calibration	-25.0 ~ 25.0	°C/°F	Resolution: 0.1°C	0.0
P1	Display 1/10th in Celsius	0/1		0: disable; 1: enable	1
P2	Temperature unit	0/1		0: °C; 1: °F	0
r0	Temperature hysteresis	0.1 ~ 15.0	°C/°F		2.0
r1	Low limit for set-point	-99.0 ~ r2	°C/°F		-40.0
r2	High limit for set-point	r1 ~ 199.0	°C/°F		50
r5	Control mode	0/1		0: cooling; 1: heating	0
C0	Compressor delay protection time for switching to online energizing	0 ~ 199	Min		0
C2	Compressor delay protection time for energizing	0 ~ 199	Min		3
C3	Compressor delay protection time for de-energizing	0 ~ 199	Sec		0
d0	Defrost period	0 ~ 99	Hour	0: disable defrost	8
d3	Defrost time	0 ~ 99	Min	0: disable defrost	30
d4	Defrost after online	0/1		0: disable; 1: enable	0
d5	Delay time for defrost after online	0 ~ 199	Min		0
d6	Temperature display during defrosting	0/1		0: display Troom 1: when defrost triggered, If Troom < (SP+r0), display Troom, but the highest displayed value will be (SP+r0); If Troom ≥ (SP+r0), display the rising Troom, and will lock to the highest Troom if Troom falls.	1

Code	Function	Range	Unit	Note	Default
A1	Low temperature warning point	0.0~ 199.0	°C/°F	0.0: disable; Warning point ≤ SP - A1	10.0
A4	High temperature warning point	0.0~ 199.0	°C/°F	0.0: disable; Warning point ≥ SP + A4	10.0
A6	Over temperature warning delay after online	0 ~ 199	Min		120
A7	Over temperature warning delay	0 ~ 199	Min		15
I1	External input warning mode	0/1		0: Normal open (Close effective) 1: Normal close (Open effective)	0
I5	External input warning type	0/1/2/3		0: disable 1: external warning 2: compressor pressure warning 3: door open warning	<b>3</b>
I7	External input warning delay	-1 ~ 120	Min	-1: disable	30

**Note: Please close the door to test the control function, or set I5=0, else no output!**

## Control Function

### Online/Offline

Keep [set] key depressed for 4 seconds to switch between online and offline.

When in offline status, the  displays.

**The settings and status are memorized, even the power supply loses.**

### Cooling Control

When  $T_{room} \geq (SP + r_0)$ , and the output has been de-energized for C2 (C0 if after online), the output will be energized.

When  $T_{room} \leq SP$ , and the output has been energized for C3, the output will be de-energized.

### Defrost Control (only in cooling mode)

#### Automatic Defrost Control

For every d0 time, control will start a defrost process, the output will be de-energized.

A defrost process will finish after d3 time, then exit and start cooling control.

#### Manually forced Defrost

Keeping [▲] key depressed for 4 seconds to start forced defrost, the output will be de-energized.

After d3 time, the defrost ends, and start cooling control.

#### Defrost after online (when d4 = 1)

When switched to online, after d5 time, start defrosting, the output will be de-energized.

After d3 time, the defrost ends, and start cooling control.

### Heating Control

When  $T_{room} \leq (SP - r_0)$ , and the output has been de-energized for C2 (C0 if after online), the output will be energized.

When  $T_{room} \geq SP$ , and the output has been energized for C3, the output will be de-energized.

### External Warning Control

If parameter I5 = 1, and external input has been effective for I7 time, warn starts, display "IA".

If parameter I5 = 2, compressor pressure warn starts, output de-energized, display "IA".

If parameter I5 = 3, and external input has been effective for I7 time, door open warn starts, output de-energized, display “Id”.

**Temperature Warning**

When Troom ≥ (SP + A4) for A7 (A6 if after online), warn starts, display “AH”.

When Troom ≤ (SP - A1) for A7 (A6 if after online), warn starts, display “AL”.

Note: This warning does not influence the output control.

During defrosting, there will be no temperature warning.

**Sensor Calibration**

If there is tolerance for sensor, it can be calibrated by parameter o1.

**Keypad Lock**

Keeping [set] and [▼] depressed for 3 seconds to lock/unlock the keypad.

When locked, and when any key pressed in this status, display “Lo” for 3 seconds.

When unlocked, display “Un” for 3 seconds.

**Installation**

1<sup>st</sup>: Insert into drilling hole

2<sup>nd</sup>: Clamp

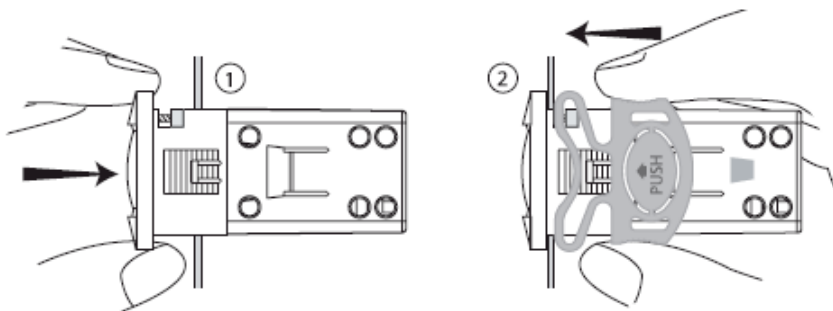

**Attention**

- Wiring should be manipulated by certified technicians;
- Supplied power should within specification requirement;
- Sensor and input signal bundles should not be laid together with power supply bundles, in same pipe;
- Sensor’s bundle is better as short as possible. Not wind the redundant length bundle to electrical noise equipment.
- Don’t touch inside components;
- Equip safety devices for equipment for equipment protection and human safety. Before supply power, check wiring again.

**Electrical Wiring Diagram**

