

ZL-7850R Temperature and Humidity Controller

Version 1.0d

Feature

- Sensor cable could be extended to 50 meters.
- Supper high humidity control with the optional sensor ZL-SHr05P.
- High absolute temperature accuracy.
- Output R1: Could be energized when over hot and/or over wet. Could drive an air exhausting fan, or an alarming indicator.
- Two timers: One timer output is R1, could drive an air exhausting fan periodically.
- Another timer outputs R4 and R5 could drive such as incubator egg tray.
- RS485 communication.

Function

- Besides the function introduced in **Feature**:
 - Heating / Cooling mode option.
 - Humidifying / de-humidifying mode option.
 - R4 and R5 could be energized by keys, suitable for control the egg tray to any angle.
 - Hight / low temperature / humidity alarm.
 - Sensor failure alarm and outputs protection.
 - Running status saving for power supply failure.
 - Calibration for temperature and humidity.
 - Temperature and humidity output delay protection.

Specification

- Power supply: 100 ~ 240Vac, 50/60Hz
- Sensor: Factory provided cable length is 2 meters
- Accuracy: Temperature: 1% / 25°C
 - Humidity: ±3% (with the sensor ZL-SHr05J)
 - ±2% (with the sensor ZL-SHr05P)
- Setting range: Temperature: 0.0 ~ 65.0°C
 - Humidity: 0 ~ 80%RH (when U9 = 0 for ZL-SHr05J)
 - 0 ~ 99%RH (when U9 = 1 for ZL-SHr05P)
- Display range: Temperature: -20. ~ 80.0°C
 - Humidity: 0 ~ 99%RH
- Outputs: Temperature control: R3 ≤ 5A
 - Humidity control: R2 ≤ 3A
 - Multi-function: R1 ≤ 3A
 - Timer outputs: R4 and R5 ≤ 1A
- Working environment:
 - 10 ~ 45°C, no more than 85%RH, without dew
- Case dimension: W78 x H34.5 x D71 (mm)
- Installation drilling: W71 x H29 (mm)
- Case materials: PC + ABS, fireproof
- Protection level: IP65 (Front side only)

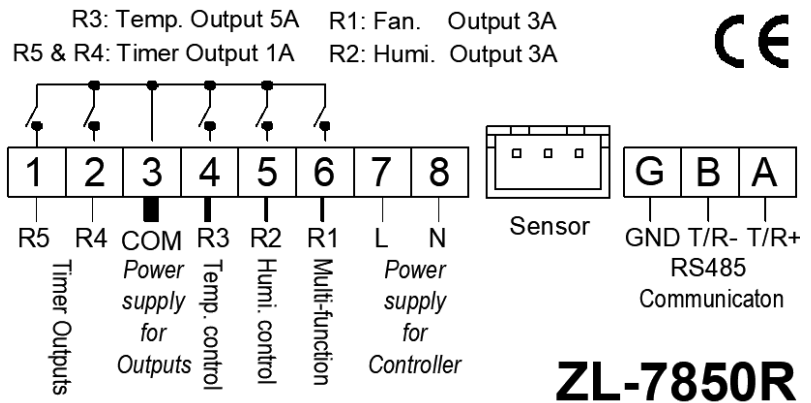

Display

Model and version display

After power supplied, the controller will display the model "7850R" and the version "1.0":



Display information

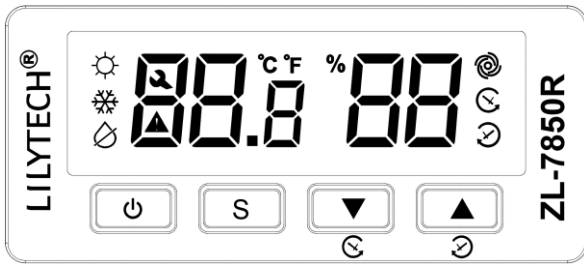

Icon	Function	On	Blink	Off
☀	Heat output (R3)	Energized	Keeping de-energized because of delay protecting (ref. 【t2】 , 【h2】)	De-energized
❄	Cool output (R3)			
💧	Humidify output (R2)			
🍃	Dehumidify output (R2)			
🌀	Multifunction output (R1)	Energized by timer	Energized by over hot / wet	
🕒	Timer output (R4)	Energized	R4 and R5 flipped times has reached 【u2】	
🕒	Timer output (R5)			
°C	Celsius	Celsius value	Setting temperature	
%	Relative humidity	Humidity value	Setting humidity	
⚠	Alarm		Alarming	No alarming
🔧	Maintenance		Has fault	No fault
E01	Sensor failure		Sensor failure alarm	
tHi	Temperature high alarm point		High temperature alarm	
tLo	Temperature low alarm point		Low temperature alarm	
hH	Humidity high alarm point		High humidity alarm	
hL	Humidity low alarm point		Low humidity alarm	
Lo	Keypad locked	Keypad locked		
Un	Keypad unlocked	Keypad unlocked		
UnL	Restore to factory default settings	Restoring to default settings		

Operation

On/Off

Keep key [🔌] depressed for 2 seconds to switch the controller between online and offline.

When in offline status, display “OF” .

Set temperature and humidity

Factory default setting: temperature is 37.8°C, humidity is 60%RH.

Press key [S] to enter into/exit temperature and humidity setting status.

At the setting status, display shows “set-value TP” or “set-value HP”.

Press [🔌] to switch between temperature setting (TP) and humidity setting (HP).

Press [▲] or [▼] to set the value. Keep depressed could fast set.

Keep [S] for 2 seconds to save the settings and exit the setting status.

The setting status will exit **without** saving the settings if there is no key operation for 15 seconds.

Set parameters

Keep [S] depressed for 5 seconds to enter into parameter setting status.

At the setting status, display shows “parameter-value parameter-code”.

Press [S] or [⏻] to select parameter code.

Press [▲] or [▼] to set the value of the code. Keep depressed could fast set.

Keep [S] for 5 seconds to save the settings and exit the setting status.

The setting status will exit **without** saving the settings if there is no key operation for 15 seconds.

System parameter table

Code	Function	Range	Remark	Factory Default
t0	Temperature control mode	H/C	H: heat; C: cool	H
t1	Temperature control hysteresis	0.1 ~ 20.0°C		0.1
t2	Time delay protection for Temperature load	0 ~ 30 min		0
t3	Temperature calibration	-9.9 ~ +9.9°C		0.0
t4	Over high temperature point (relative value)	0.0 ~ 20.0°C	If 0.0, disable the protection	0.2
t5	Over high temperature hysteresis	0.0 ~ 20.0°C	If 0.0, disable the protection	0.1
t6	High temp. alarm point (relative value)	0.0 ~ 65.0°C	If 0.0, disable the function	0.0
t7	Low temp. alarm point (relative value)	0.0 ~ 65.0°C	If 0.0, disable the function	0.0
h0	Humidity control mode	H/P	H: humidify; P: dehumidify	H
h1	Humidity control hysteresis	1 ~ 20%RH		2
h2	Time delay protection for Humidity load	0 ~ 30 min		0
h3	Humidity calibration	-20 ~ +20%RH		0
h4	Over high humidity point (relative value)	0 ~ 20%RH	If 0, disable the protection	5
h5	Over high humidity hysteresis	0 ~ 20%RH	If 0, disable the protection	2
h6	High humidity alarm point (relative value)	0 ~ 80%RH	If 0, disable the function	0
h7	Low humidity alarm point (relative value)	0 ~ 80%RH	If 0, disable the function	0
u0	R4 / R5 de-energized time	0 ~ 999 min	If 0, stop the timer function	60
u1	R4 / R5 energized time	0 ~ 999 sec	If 0, stop the timer function	30
u2	Times for R4 and R5 switching	0 ~ 999	If 0, switching without stop	0
u3	R1 de-energized time	0 ~ 999 min	If 0, stop the timer function	120
u4	R1 energized time	0 ~ 999 sec	If 0, stop the timer function	30
u7	RS485 baud rate (bps)	0 ~ 3	0: 2400 1: 4800 2: 9600 3: 19200	2
u8	Modbus address	1 ~ 255		1
u9	Sensor selection	0/1	0: ZL-SHr05J; 1: ZL-SHr05P	0

Control

Multifunction Output R1

Over hot / wet protection: If R1 drives an exhaust fan, it has the function to cool down or dry quickly.

Ref. to **Temperature control** -> **Over hot protection**, and **Humidity control** -> **Over wet protection**.

Timer output: R1 will be energized for [u4] after de-energized for [u3], periodically.

Temperature control

Heat mode [t0 = H]

If **Room temp.** ≤ **Set temp. (TP)** – [t1], and **Temp. Output (R3)** has stopped for [t2], then **Temp. Output** will be energized.

If **Room temp.** ≥ **Set temp.**, then **Temp. Output** will be de-energized.

Cool mode 【t0 = C】

If **Room temp.** \geq **Set temp.** + 【t1】, and **Temp. Output** has stopped for 【t2】, then **Temp. Output** will be energized.

If **Room temp.** \leq **Set temp.**, then **Temp. Output** will be de-energized.

Over hot protection

If **Room temp.** \geq **Set temp.** + 【t4】, then output R1 will be energized.

If **Room temp.** \leq **Set temp.** + 【t4】 - 【t5】, then output R1 will be de-energized.

This protection function is only effective in heat mode.

If 【t4】 = 【t5】 = 0.0, disable the protection function.

Humidity control**Humidify mode 【h0 = H】**

If **Room humidity** \leq **Set humidity (HP)** - 【h1】, and **Humi. Output** (R2) has stopped for 【h2】, then **Humi. Output** will be energized.

If **Room humidity** \geq **Set humidity**, then **Humi. Output** will be de-energized.

Dehumidify mode 【h0 = P】

If **Room humidity** \geq **Set humidity** + 【h1】, and **Humi. Output** has stopped for 【h2】, then **Humi. Output** will be energized.

If **Room humidity** \leq **Set humidity**, then **Humi. Output** will be de-energized.

Over wet protection

If **Room humidity** \geq **Set humidity** + 【h4】, then output R1 will be energized.

If **Room humidity** \leq **Set humidity** + 【h4】 - 【h5】, then output R1 will be de-energized.

This protection function is only effective in humidify mode.

If 【h4】 = 【h5】 = 0.0, disable the protection function.



Timer output R4 and R5

R4 and R5 are controlled by parameter 【u0】, 【u1】 and 【u2】.

R4 and R5 will be energized for 【u1】 time alternatively. A period includes an R4 energized and an R5 energized.

There is a counter counting the times of the period. Every time after the power supplied, the counting value is reset to zero.

keeping 【S】 and 【▼】 depressed simultaneously will show the counting value for 3 seconds.

If 【u2】 > 0, when the counting value reaches 【u2】, R4 and R5 will stop energized, and display  and  will blink.

If 【u2】 is set to zero, R4 and R5 will never stop energized.

Forced energized manually:

Keeping 【▲】 depressed for 2 seconds makes R5 being energized, until the key is released.

Keeping 【▼】 depressed for 2 seconds makes R4 being energized, until the key is released.

R4 and R5 could be used for incubator egg tray control.

Alarm

High temp. alarm: if **Room temp.** \geq **Set temp.** (TP) + 【t6】, display “tHi”. If 【t6】 = 0.0, the function disable.

Low temp. alarm: if **Room temp.** \leq **Set temp.** - 【t7】, display “tLo”. If 【t7】 = 0.0, the function disable.

High humidity alarm: if **Room humidity** \geq **Set humidity (HP)** + 【h6】, display “hH”. If 【h6】 = 0.0, the function disable.

Low humidity alarm: if **Room humidity** \leq **Set humidity** - 【h7】, display “hL”. If 【h7】 = 0.0, the function disable.

Sensor

The **Room temp.** can be calibrated. If **Room temp.** is 0.2°C lower than real temp., set 【t3】 = 0.2.

The **Room humidity** can be calibrated. If **Room humidity** is 2%RH higher than real, set 【h3】 = -2.

When sensor fails, the **Temp. and Humi. Output** (R3, R2) will not be energized, and “E01” will display.

Note: do not plug in/off the sensor when power supplied.

Keypad lock

Keep [S] and [P] depressed simultaneously for 3 seconds to lock the keypad, "Lo" displays for 3 seconds.

When keypad locked, any key press will not be executed, but display "Lo".

Keep [S] and [P] depressed simultaneously for 3 seconds to unlock, "Un" displays for 3 seconds.

Restore settings to factory default set

Keep [P] and [▲] depressed simultaneously for 3 seconds, "UnL" displays.

Then press [▼] twice, all parameter settings will restore to factory default set value.

Attention

1. Do not connect wiring when power is supplied.
2. Electrical wiring must be manipulated by certified electrician.
3. Read this manual carefully. Connect according to electrical wiring diagram. Wrong connection will damage the device.
4. Do not lay the sensor bundle together with power supply bundle.
5. Avoid working in erosive, wet, strong electrical-magnetic field environment.
6. This device has been checked fully before shipment. The warranty time is one year, damaged by wrong usage, such as wrong connection, is not warranted.

Installation

1st: Insert into drilling hole

2nd: Clamp

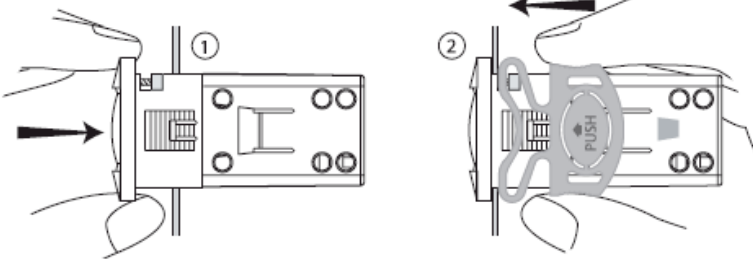

Wiring diagram

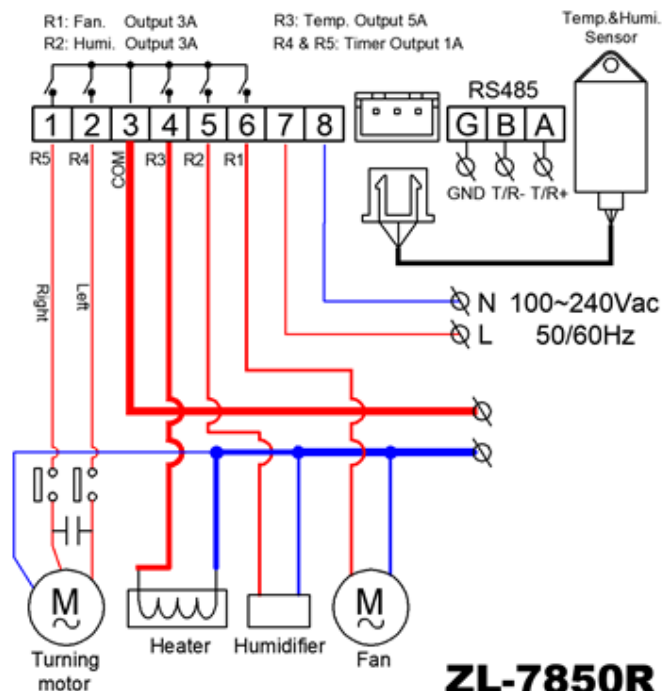

Communication

Port setting

Mode: Serial Asynchronous half duplex

Baud rate (bps): 2400, 4800, 9600(default), or 19200

Data bit: 8 (LSB 1st)

Parity check: none

Start bit: 1

Stop bit: 1

Modbus function

Coil table

Coil Address	Type	Description	R/W	Remark	Modbus Command
1	bit	Sensor failure	R	0: no problem, 1: fail	0x01
6	bit	High temperature alarm	R	0: no alarm, 1: alarm	0x01
7	bit	Low temperature alarm	R	0: no alarm, 1: alarm	0x01
8	bit	High humidity alarm	R	0: no alarm, 1: alarm	0x01
9	bit	Low humidity alarm	R	0: no alarm, 1: alarm	0x01
12	bit	R4/R5 period counting reached to U2	R	0: not reached, 1: reached	0x01
14	bit	R1 status	R	0: de-energized, 1: energized	0x01
15	bit	R2 status	R	0: de-energized, 1: energized	0x01
16	bit	R3 status	R	0: de-energized, 1: energized	0x01
17	bit	R4 status	R	0: de-energized, 1: energized	0x01
18	bit	R5 status	R	0: de-energized, 1: energized	0x01
20	bit	R4 is forced energized manually	R	0: not forced, 1: forced energized	0x01
21	bit	R5 is forced energized manually	R	0: not forced, 1: forced energized	0x01
22	bit	Timing moment for R4 or R5	R	0: timing for R5, 1: timing for R4	0x01
25	bit	Controller on/offline	R/W	0: offline, 1: online	0x01/0x05
26	bit	Keypad lock	R/W	0: unlocked, 1: locked	0x01/0x05
29	bit	R4/R5 period counting reset	W	Write 1 will clear the counter value	0x05
30	bit	Force control R4	W	Write 1, R4 will be energized for U1 time Write 0, de-energize R4	0x05
31	bit	Force control R5	W	Write 1, R5 will be energized for U1 time Write 0, de-energize R5	0x05

Register table (see next page)

Register table

Register Address	Type	Remark	R/W	Value	Unit	Default	Remark	Modbus Command
1	int	Room temp.	R	-20.0 ~ 80.0	°C		Value * 10	0x03
2	int	Room humidity	R	0.0 ~ 99.0	%RH		Value * 10	0x03
3	int	R4/R5 De-energized time	R	0 ~ 999	Min			0x03
4	int	R4/R5 Energized time	R	0 ~ 999	Sec			0x03
5	int	R1 De-energized time	R	0 ~ 999	Min			0x03
6	int	R1 Energized time	R	0 ~ 999	Sec			0x03
9	int	t0 Cool/heat mode	R/W	12/22		22	12: cool, 22: heat	0x03/0x06/0x10
10	int	t1 Temp. hysteresis	R/W	0.1 ~ 20.0	°C	0.1	Value * 10	0x03/0x06/0x10
11	int	t2 Delay protection for temp. load	R/W	0 ~ 30	Min	0		0x03/0x06/0x10
12	int	t3 Temp. calibration	R/W	-9.9 ~ +9.9	°C	0	Value * 10	0x03/0x06/0x10
13	int	t4 Over high temp. point	R/W	0.0 ~ 20.0	°C	0.2	Value * 10	0x03/0x06/0x10
14	int	t5 Over high temp. hysteresis	R/W	0.0 ~ 20.0	°C	0.1	Value * 10	0x03/0x06/0x10
15	int	t6 High temp. alarm point	R/W	0.0 ~ 65.0	°C	0	Value * 10	0x03/0x06/0x10
16	int	t7 Low temp. alarm point	R/W	0.0 ~ 65.0	°C	0	Value * 10	0x03/0x06/0x10
17	int	h0 Humidify/de-humidify mode	R/W	17/22		22	17: dry, 22: humidify	0x03/0x06/0x10
18	int	h1 Humidify hysteresis	R/W	1.0 ~ 20.0	%RH	2.0	Value * 10	0x03/0x06/0x10
19	int	h2 Delay protection for humidity load	R/W	0 ~ 30	Min	0		0x03/0x06/0x10
20	int	h3 Humidity calibration	R/W	-20.0 ~ +20.0	%RH	0.0	Value * 10	0x03/0x06/0x10
21	int	h4 Over high humidity point	R/W	0.0 ~ 20.0	%RH	5.0	Value * 10	0x03/0x06/0x10
22	int	h5 Over high humidity hysteresis	R/W	0.0 ~ 20.0	%RH	2.0	Value * 10	0x03/0x06/0x10
23	int	h6 High humidity alarm point	R/W	0.0 ~ 80.0	%RH	0.0	Value * 10	0x03/0x06/0x10
24	int	h7 Low humidity alarm point	R/W	0.0 ~ 80.0	%RH	0.0	Value * 10	0x03/0x06/0x10
25	int	u0 R4/R5 De-energized time	R/W	0 ~ 999	Min	60		0x03/0x06/0x10
26	int	u1 R4/R5 Energized time	R/W	0 ~ 999	Sec	30		0x03/0x06/0x10
27	int	u2 Allowed times for R4/R5 period	R/W	0 ~ 999		0		0x03/0x06/0x10
28	int	u3 R1 De-energized time	R/W	0 ~ 999	Min	120		0x03/0x06/0x10
29	int	u4 R1 Energized time	R/W	0 ~ 999	Sec	30		0x03/0x06/0x10
30	int	u7 RS485 baud rate (bps)	R/W	0 ~ 3		2		0x03/0x06/0x10
31	int	u8 Modbus address	R/W	1 ~ 255		1		0x03/0x06/0x10
32	int	u9 Sensor selection	R/W	0/1		0		0x03/0x06/0x10
33	int	Temp. set point	R/W	0.0 ~ 65.0	°C	37.8	Value * 10	0x03/0x06/0x10
34	int	Humidity set point	R/W	0.0 ~ 99.0	%RH	60.0	Value * 10	0x03/0x06/0x10
35	int	Counter for R4/R5 period	R/W	0 ~ 999		0		0x03/0x06/0x10
36	int	Restore to factory default settings	R/W	0/1		0	1: restoring	0x03/0x06/0x10