

ZL-7901A Intelligent Temperature and Humidity Controller

Instruction Manual

V2.6

Feature

ZL-7901A is an industrial intelligent temperature and humidity controller. Optional external SSR to realize bigger heating power rate, and with optional temperature PID control. With touch button and big size LCD display, convenient to operate, easy to set up. Applicable for control of incubator, climate chamber, warehouse, and so on.

Main Function

1. Three temperature control modes: relays up/down limit control, SSR up/down limit control, SSR PID control
2. Humidify or dehumidify control
3. Timer air exhaust control
4. Timer egg turning control
5. Illumination control
6. Alarm output
7. Auto restart function
8. Temperature/humidity over limit warning and protection
9. Temperature/humidity sensor fault warning and protection

Specification

- ◇ Power supply: 100~240VAC, 50 or 60Hz
- ◇ Output and input:

Output				Input	
Main heater control relay	250VAC	7.5A	Resistive load	R1	NTC temperature sensor, 5K/3470
Aux heater control relay		7.5A		R2	Humidity sensor SHR04
Humidity control relay		7.5A		R3	
Lamp control relay		7.5A		R4	
Air exhaust control relay		3A		R5	
Egg turning relay		1A		R6/R7	
Alarm output relay		1A		R8/R9	
SSR driver	20mA/10VDC MAX			Y+/Y-	





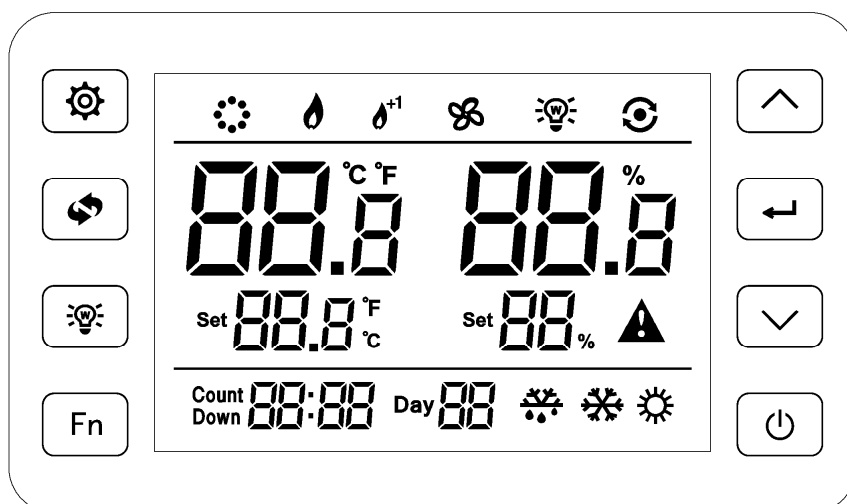

- ◇ Setting range: humidity 0~99% RH, temperature 0~100°C
- ◇ Measuring absolute accuracy before calibration: temperature 1%@25°C, humidity 3%@25°C
- ◇ Working environment: -20~45°C, 10~90% RH without dewing

Product Version







When power supplied, the controller will display model and firmware version: **ZL-7901A, version 2.6:**

Key and Display



Key	Function	Remark
	Power	Keep depressed for 3 seconds to turn online/offline
	Set	Short press to switch between humidity set and temperature set; Long press to set other parameters (see Parameter Table below)
	+	Increase the set value. Keep depressed for fast set
	-	Decrease the set value. Keep depressed for fast set
	Enter	Confirmation
	Reset	Short press for cancel and return; Long press to clear incubating accumulated days counter
	Lamp	Turn the lamp off/on
Fn	Fn	Combination key

Display Remark

Icon	Function	On	Off	Blinking
	Humidify/dehumidify state	Energized	De-energized	
	Main heater	Energized	De-energized	
	Auxiliary heater	Energized	De-energized	
	Air exhaust	Energized	De-energized	
	Egg turning motor, turn right	Energized	De-energized	
	Egg turning motor, turn left	Energized	De-energized	
	Warning	---	No warning	Warning
E01	Temperature sensor fault	Warning	No warning	
E02	Humidity sensor fault	Warning	No warning	
tHi	Temperature higher than up limit	Warning	No warning	
tLo	Temperature lower than down limit	Warning	No warning	
HHi	Humidity higher than up limit	Warning	No warning	
HLo	Humidity lower than down limit	Warning	No warning	
UnL	Restore to default parameters	Restoring to default parameters		

Buzzing

Every key press, there will be a beep.

When there is error of sensors, high/low limit temperature or humidity warning, there will be buzzing warning. Any key press can stop the warning.

Key Operation



Fast Set Temperature (T11), Fast Set Humidity (H20)



Press  to switch between temperature and humidity setting. Press  and  to set the value.

Press  to save the setting.





Press , or without key operation for 30 seconds, exit the mode, and the set value is not saved.

Parameters Setting

Keep  and  depressed simultaneously for 3 seconds. LCD shows "Psd 000".

Press  and  to enter password (default "000"). Press  to confirm.

If the password is correct, enter into parameters setting mode, else exit.

Press  to select parameter code, press  and  to set the value, press  to save the setting.

Press , or without key operation for 30 seconds, exit the mode, and the set value is not saved.

Parameter Table

Code	Function	Range	Unit	Indication	Default
T10	Temperature control mode (R1, R2, SSR)	0~2		0 = R1 + R2, up/down limit control 1 = External SSR, up/down limit control 2 = External SSR, PID control	0
T11	Temperature set point	T24~T23	°C/°F		37.8
T12	Main (R1) temperature hysteresis	0~20.0	°C/°F	Relative to T11	0.2
T13	Aux. (R2) temperature hysteresis	0~20.0	°C/°F	Relative to T11	0.3
T14	Min stop time for main temperature control (R1)	0~999	sec		1
T15	Min stop time for aux. temperature control (R2)	0~999	sec		1
T16	Min stop time for SSR temperature control	0~999	sec		1
T20	Temperature calibration	-9.9~+9.9	°C/°F		0
T21	High temp. warning relative point	0.1~20.0	°C/°F	Ref.: U20=1/2/3, U30=2/3/4, U40=2/3/4 Hi temp. warning absolute point=T11+T21	0.3
T22	Low temp. warning relative point	0.1~100	°C/°F	Ref.: U40=2/3/4 Low temp. warning absolute point=T11-T22	37.8
T23	Temperature set point up limit	T24~100	°C/°F	The up limit for T11	38.5
T24	Temperature set point down limit	0~T23	°C/°F	The down limit for T11	35
T30	Proportion of SSR PID	0.1~5000	Power/°C	Kp for PID	39.3
T31	Integration of SSR PID	0~5000	sec	Ti for PID. If Ti = 0, shut integration.	15.7
T32	Differential of SSR PID	0~5000	sec	Td for PID. If Td = 0, shut differential.	40.5
H10	Dehumidify / humidify mode	0~1		0 = dehumidify, 1 = humidify	1
H20	Humidity set point	0~99	%		50
H21	Humidity hysteresis	0~50	%		5
H22	Humidity calibration	-9.9~+9.9	%		0
H23	Min stop time for humidity control (R3)	0~30	min		0
H24	High humidity warning relative point	1~99	%	Ref.: U20=1/2/3, U30=2/3/4, U40=2/3/4 Absolute point=H20+H24	5
H25	Low humidity warning relative point	1~99	%	Ref.: U40=2/3/4 Absolute point=H20-H25	45
U10	Left turn (R6) time unit	1~2		1 = minute, 2 = hour	1
U11	Left turn (R6) time of the timer	1~999			120
U12	Right turn (R7) time unit	1~2		1 = minute, 2 = hour	1
U13	Right turn (R7) time of the timer	1~999			120
U14	Turning times	0~999		0 = unlimited turning times	0
U16	Turning motor working mode	0~1		0: Either R6 or R7 will be energized. Need position switches, position arrival shuts off the power supply to motor 1: Only energized during turning moment (U17). Manual egg turning support	1
U17	Motor being energized time for every turning	0~999	sec	Effective only when U16 = 1	30
U18	Hatching days	0~99	day	0 = disabled hatching days counting	0

Parameter Table (continued)

Code	Function	Range	Unit	Indication	Default
U20	Air exhaust control mode (R5)	0~3		0 = Air exhaust 1 = Air exhaust + humidity/temperature high limit protection 2 = Air exhaust + temperature high limit protection 3 = Air exhaust + humidity high limit protection	1
U21	Time unit for air exhaust period (R5)	0~2		0 = second, 1 = minute, 2 = hour	1
U22	Air exhaust period (R5)	1~999			30
U23	Time unit for air exhausting time (R5)	0~2		0 = second, 1 = minute, 2 = hour	0
U24	Air exhausting time (R5)	1~999			30
U30	Lamp relay function (R4)	0~4		0 = illumination control 1 = timer switch control 2 = temperature and humidity high limit protection 3 = Temperature high limit protection 4 = humidity high limit protection	0
U31	Time unit for period (R4, when U30 = 1)	0~2		0 = second, 1 = minute, 2 = hour	0
U32	Period (R4, when U30 = 1)	1~999			120
U33	Time unit for timer's time (R4, when U30 = 1)	0~2		0 = second, 1 = minute, 2 = hour	1
U34	Timer's time (R4, when U30 = 1)	1~999			5
U40	Alarm relay mode and function (R8, R9)	0~4		0 = alarm output 1 = timer switch control 2 = temperature and humidity high/low limit alarming 3 = temperature high/low limit alarming 4 = humidity high/low limit alarming	0
U41	Time unit for period (R8, when U40 = 1)	0~2		0 = second, 1 = minute, 2 = hour	1
U42	Period (R8, when U40 = 1)	1~999			120
U43	Time unit for timer's time (R8, when U40 = 1)	0~2		0 = second, 1 = minute, 2 = hour	1
U44	Timer's time (R8, when U40 = 1)	1~999			5
U65	Buzzing warning option	0~1		0: disable warning, 1: enable warning	1
U90	Password	000~999		000 = no password	0
U93	PID self auto tune power rate	10~100	%	Percent of heater's full power rate	50
End					

Control Function

On/off: Keep \odot depressed for 3 seconds to switch between online and offline. The controlling only works when online.

Temperature Control (R1, R2, SSR)

1. Main temperature control (R1) + Auxiliary control (R2) (T10 = 0)

If room temp. \leq (T11 - T12), and main temp. control (R1) has been stopped for T14, R1 will be energized.

If room temp. \geq T11, main temp. control (R1) will be de-energized.

If room temp. $<$ (T11 - T13), and auxiliary temp. control (R2) has been stopped for T15, R2 will be energized.

If room temp. \geq (T11 - T13), auxiliary temp. control (R2) will be de-energized.

2. External SSR hysteresis control (T10 = 1)

If room temp. \leq (T11 - T12), and SSR has been stopped for T16, SSR will be energized.

If room temp. \geq T11, SSR will be de-energized.

3. External SSR PID control (T10 = 2)

Auto Tuning is able to find PID parameters (Kp/Ti/Td, U30/31/32) automatically for most control system

1. Set power rate during auto tuning (U93).
 2. Set set-point during auto tuning (SP, T11).
- When not in set mode, keep Fn and \checkmark depressed simultaneously for 5 seconds to enter into self auto tuning mode: LCD will display "Pid". Press \leftarrow to start tuning. Then LCD will display "At".
- After the room temperature (PV) reached SP, it will vibrate around SP for several times. The controller will calculate the PID parameters (Kp/Ti/Td, U30/31/32) according to these PV data. And the "At" display disappears.

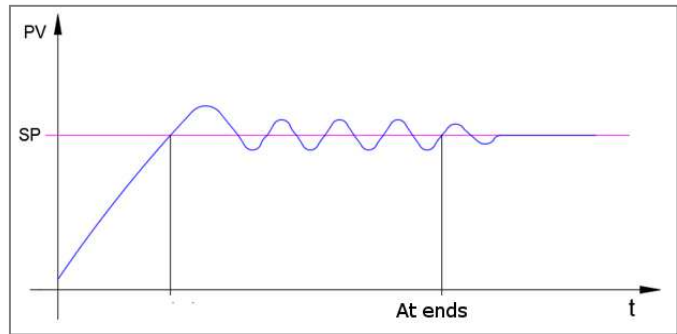

Note:

a. PID control, or hysteresis control?

Try hysteresis control 1st (T10 = 1):

- Now is full power rate heating. If PV is not able to reach SP within reasonable time, increase heater power rate.
- If PV overshoot to $SP \leq 0.2^{\circ}C$, or over falling to $(SP - T12) \leq 0.2^{\circ}C$: auto tuning is not able to get the PID parameters correctly.
- If all are ok, try PID auto tuning.

Try auto tuning (T10 = 2, start auto tuning):

Now the heating power rate is U93 percent of the heater's power rate. Default U93 = 50.

If PV is not able to reach SP within reasonable time, increase U93 value, or increase heater power rate.

If the overshoot or over falling to $SP \leq 0.2^{\circ}C$, auto tuning is not able to get the PID parameters correctly.

The following will also make auto tuning failure, or get wrong PID parameters:

- The PV vibration amplitudes differ too much.
- The PV vibration periods differ too much.
- The PV changes not smoothly (there are temperature interference, like opened door at some moment).

b. Try to get best parameters

If make 2 auto tuning, the tuned PID parameters are similar, we could use the average data for application. If the 2 tuned data are not similar, auto tuning the 3rd times.

When the environment temperature, or object inside (empty box and box with goods inside are not same system), or air flow speed inside changed greatly, it needs auto tuning again.

c. About PTC heating element

PTC has a Curie point parameter. When PTC's temperature is high than Curie point, its power rate will be reduced to almost zero, the PID control will fail.

With higher Curie PTC heater, with good dissipator for heater, with high air flow speed around heater to avoid the failure.

d. Manual tuning principle

Manual tuning could revise the control result. $Kp = U30$, $Ti = U31$, $Td = U32$.

Increase Kp, increase the speed of control, but more overshoot and bigger vibration.

Increase Ti, get more accurate temperature, but need longer time to reach SP after stating heating.

Increase Td, fast reaction to control, but add more "noise" to the control result.

Humidity Control (R3)

Humidify control (H10 = 1)

If room humidity $\leq (H20 - H21)$, and R3 has stopped for H23, R3 will be energized.

If room humidity $\geq H20$, R3 will be de-energized.

Dehumidify control (H10 = 0)

If room humidity $\geq (H20 + H21)$, and R3 has stopped for H23, R3 will be energized.

If room humidity $\leq H20$, R3 will be de-energized.

Egg-turning Control (R6, R7)

Mode 0 (U16 = 0): Either R6 or R7 will be energized, need position switches, manual turning does not work.

When left turning time (U11) arrives, R6 energized, R7 de-energized.

When right turning time (U13) arrives, R7 energized, R6 de-energized.

Mode 1 (U16 = 1): R6 and R7 is not energized when no turning, manual turning works.

When left turning time (U11) arrives, R6 energized for U17.

When right turning time (U13) arrives, R7 energized for U17.

Manual turning:

Keep \wedge and \vee depressed simultaneously for 3 second to enter into the mode, R6 and R7 will be de-energized, the \bullet display will be flashing;

If keep \wedge depressed, R6 energized, \odot displayed;

If keep \vee depressed, R7 energized, \odot displayed;

Keep \wedge and \vee depressed simultaneously for 3 sec, or no key operation for 30 sec will exit the mode.

Egg turning times:

R6 starts once + R7 starts once = turning once. When egg turning times reaches U14, turning will not start any more.

If turning times (U14) = 0, turning will never stop.

Check left times of egg turning and time to the next egg turning:

When turning times (U14) \neq 0, the *left times of egg turning* and *time to the next egg turning* will display alternatively.

When the *accumulated times of egg turning* \geq U14, LCD will display "STOP", there will be no egg turning.

Keeping \odot depressed for 3 seconds will reset the *accumulated times of egg turning* and *incubation day counter*.

When turning times (U14) = 0, the egg turning will never stop. LCD will display *time to the next egg turning*.

Air Exhaust Control (R5)

Air exhaust mode (U20 = 0)

When U22 arrives, R5 is energized;

When U24 arrives, R5 is de-energized.

Air exhaust + temperature and humidity over limit protection mode (U20 = 1)

When there is no warning, controller works as air exhaust mode (U20 = 0).

When there is high temperature warning (T21) or humidity warning (H24), R5 energized;

When the warning disappears, R5 de-energized.

Air exhaust + temperature over limit protection mode (U20 = 2)

When there is no warning, controller works as air exhaust mode (U20 = 0).

When there is high temperature warning (T21), R5 energized;

When the warning disappears, R5 de-energized.

Air exhaust + humidity over limit protection mode (U20 = 3)

When there is no warning, controller works as air exhaust mode (U20 = 0).

When there is high humidity warning (H24), R5 energized;

When the warning disappears, R5 de-energized.

Lamp Control (R4)

Illumination control mode (U30 = 0): Press \odot to turn the lamp on/off.

Timer switch control mode (U30 = 1): R4 is de-energized during U32, energized during U34, repeatedly.

Temperature and humidity over limit protection mode (U30 = 2)

When there is high temperature warning (T21) or humidity warning (H24), R4 energized;

When the warning disappears, R4 de-energized.

Temperature over limit protection mode (U30 = 3)

When there is high temperature warning (T21), R4 energized;

When the warning disappears, R4 de-energized.

Humidity over limit protection mode (U30 = 4)

When there is high humidity warning (H24), R4 energized;

When the warning disappears, R4 de-energized.

Warning Output Control (R8, R9)

Alarm output mode (U40 = 0)

R8: energized when there is fault, de-energized when no fault;

R9: de-energized when there is fault, energized when no fault.

When temperature or humidity sensor fails, warning output energized. Temperature or humidity control output will be de-energized. Other control outputs keep working.

Timer switch control mode (U40 = 1): R8 is de-energized during U42, energized during U44, repeatedly.

Temperature and humidity over limit protection mode (U40 = 2)

When there is high temperature warning (T21) or humidity warning (H24), R8 energized;

When the warning disappears, R8 de-energized.

Temperature over limit protection (U40 = 3)

When there is high temperature warning (T21), R8 energized;

When the warning disappears, R8 de-energized.

Humidity over limit protection mode (U40 = 4)

When there is high humidity warning (H24), R8 energized;

When the warning disappears, R8 de-energized.

Auto Restart Function

After power supply stops, and then comes back, the controller will run under the same settings before the power supply stops.

Incubation Day Counter

When controlling, the *incubation day counter* will keep counting.
 If the counter value reaches U18, controller keeps controlling as normal, and the counter value will be flashing.
 If the counter value reaches 99, stop counting. Keeping depressed for 3 seconds will reset the *accumulated times of egg turning and incubation day counter*.

Restore to Factory Default Settings

When the controller is online, keep Fn and depressed simultaneously for 3 seconds. The display shows “UnL”. Then press twice, the controller will restore the parameters to factory default settings.

Fahrenheit/Celsius display

Keep Fn and depressed simultaneously for 3 seconds to switch between Fahrenheit / Celsius display.

Manually Checking the Outputs One by One

Keep Fn depressed for 3 seconds, LCD displays “CCC”. Then press twice to enter into manual checking mode. Now all outputs are de-energized. Press and to energize R1/R2/R3/R4/R5/R6/R7/SSR in turn.

Warning Control Instruction (unit in second)

No.	Code	Remark	Real time detection	Delay	Dura-tion	Reset	Action
1	E01	Temperature sensor fault	Yes	0s	6s	Auto	Alarming, temperature output off, the other control not affected
2	E02	Humidity sensor fault	Yes	0s	6s	Auto	Alarming, humidity output off, the other control not affected
3	tHi	Over high temperature warning point	Yes	0s	5s	Auto	Alarming
4	tLo	Lower than low temperature warning point	Yes	0s	5s	Auto	Alarming
5	HHi	Over high humidity warning point	Yes	0s	5s	Auto	Alarming
6	HLo	Lower than low humidity warning point	Yes	0s	5s	Auto	Alarming
7	iCE	Touched IC fault	Yes	0s	5s	Auto	

Attention

1. Please read this instruction carefully. Electrical wiring must be manipulated by certified electrician. Wrong wiring may damage the device and system seriously.
2. Avoid humid environment, or with corrosive gases, or strong electric-magnetic field. The device is possible abnormal in such condition.
3. This product has been strictly tested before shipping. The company warranty is one year, the responsibility is limited to the sale of the product itself. Damage caused by improper usage is not covered by the warranty.

Wiring Diagram

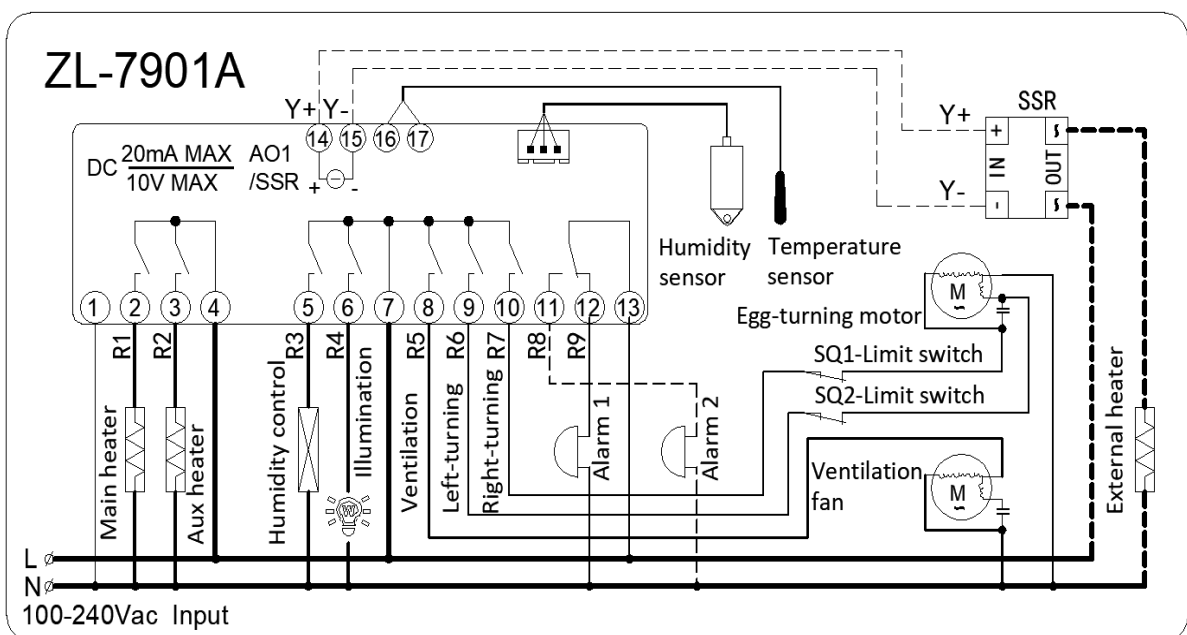

Controller Installation Dimension

